

SV18 Ballast Box



120VAC/150W
240VAC/150W

Introduction:

Congratulations on the purchase of your new thru hull light ballast box. Underwater Lights® USA, LLC takes pride in providing well designed, high quality and thoroughly tested lights that allow you to “enhance your boating experience”. These lights can be installed in your vessel for aesthetics, to attract fish, for security and safety.

Features Include:

- Latest microprocessor control technology to guarantee high levels of performance.
- Flicker free lighting and enhanced lamp life is provided by a square wave lamp current waveform.
- Constant power feature ensures excellent color maintenance throughout the extended life of the lamp.
- Transient, short circuit, thermal, open circuit, no lamp, hot lamp shutdown, retry and ignition failure protections.
- Electrical wiring terminal block with VAC input fuse protection.
- Electrical provision for “daisy chaining” of additional ballast boxes.

General Safety Information:

- This ballast box is specifically designed for use with matching Underwater Lights USA, LLC brand lights only.
- Always ensure that VAC power is disconnected and locked out before performing ballast box installation and/or service.
- The ballast box should be opened and visually inspected every six months.
- Ballast box electrical cabling should be visually inspected for proper operating condition every six months.

Technical Specifications:

- Box Dimensions = 220mm (8.66”) long x 120mm (4.72”) wide x 91mm (3.58”) deep - 1.9 kilograms (4.2 pounds)
- Box Construction = Molded gray, glass reinforced polyester with integral rubber (EDPM) gasket, IP65/NEMA 4X rated
- OR
- Box Dimensions = 221mm (8.70”) long x 121mm (4.76”) wide x 80mm (3.15”) deep - 2.1 kilograms (4.7 pounds)
- Box Construction = Gray powder coated diecast aluminum alloy with integral silicone rubber gasket, IP65/NEMA 4X rated
- Ballast = 120 VAC, 50/60 Hz, 1.38 Ampere input - 150 Watt output - Minimum operating temperature -30°C (-22°F)
- OR
- Ballast = 240 VAC, 50/60 Hz, 0.69 Ampere input - 150 Watt output - Minimum operating temperature -30°C (-22°F)
- Cable to Ballast Box = Marine grade electrical cable, 14/3 stranded copper wire, with as short a length as possible
- Cable from Ballast Box to Light = High temperature silicone cable, 16/3 shielded copper wire, 15 meters (50 feet) max length
- Terminal block fuse = Fast blow 10 Amp cylindrical, 6.3mm diameter x 25mm or 32mm long (0.25” diameter x 1.0” or 1.25” long)

Troubleshooting:

Please contact our technical support staff in Florida at 1-954-760-4447, Monday to Friday from 8:00 am to 5:00 pm EST.

Warranty:

Underwater Lights® USA, LLC warrants this ballast box to be free from defects in workmanship and materials for a period of two years from the date of original purchase. Further, misuse, abuse, improper installation, neglect, improper shipping, damage caused by disasters such as fire, flood and lightning, unauthorized repair or modifications will void said warranty. Should your ballast box prove defective during the warranty period, promptly contact Underwater Lights® USA, LLC for an RMA number and then return the ballast box freight prepaid with the RMA number clearly marked on the outside of the shipping container.

Underwater Lights USA, LLC
277 SW 33rd Court
Fort Lauderdale, FL 33315 USA
Phone: 1-954-760-4447
Fax: 1-954-525-3261
Internet: www.seavision.com
Email: sales@seavision.com



DOC:092005-8W

Underwater Lights Europe Sarl
Résidence L'Hippocampe: 19, Avenue Thiers
06600 Antibes, France
Phone: 33-(0)-4-97-21-02-96
Fax: 33-(0)-4-97-21-10-96
Internet: www.seavision.com
Email: sales@seavisioneurope.com

SV18 Ballast Box



Installation:

120VAC/150W
240VAC/150W

Select a location that affords good access to the ballast box. Preferably the ballast box should be placed in a cool, dry and well ventilated area. Attach the ballast box to a fixed wall or similar secure structure using appropriate M6 fasteners. Note: Whereas, the ballast box can be placed in any orientation, it is recommended that the cable strain relief connectors face down.

Using marine grade 14/3 cable, run a VAC input line into the ballast box and secure by way of one cable strain relief connector.

Using a high temperature 18/3 shielded silicone cable, run a line from the ballast box to the underwater light and secure each end by way of a strain relief connector. Caution! Avoid making tight bends and/or passing cable over sharp edges/surfaces.

Connect cable leads at both the ballast box and underwater light as shown in the wiring diagram below.

Optional: Using marine grade 14/3 cable, a VAC jumper line can be "daisy chained" to an additional ballast box by replacing the blanking plug with supplied cable strain relief connector as illustrated below. Note: Four ballast box maximum daisy chain.

Serviceable Parts:

Upon opening the ballast box by unscrewing four captive lid fasteners, replacement of the HID ballast and/or terminal block with fuse is accomplished by removal and replacement of three phillips pan head screws and associated wiring. Further, a 10 Amp fuse located in the fused terminal block may be pulled out and replaced as required. Caution! Ensure that VAC power is disconnected and locked out before servicing ballast box.

DESCRIPTION
ENCLOSURE, PLASTIC
ENCLOSURE, ALUMINUM
MOUNTING PLATE
TERMINAL BLOCK MOUNT
CABLE STRAIN RELIEF
BLANKING PLUG
120VAC BALLAST, MODEL 10A16B
120VAC BALLAST, MODEL 10A19B
240VAC BALLAST, MODEL 11A16B
240VAC BALLAST, MODEL 11A19B
FUSED TERMINAL BLOCK
M6 x 1.0 x 8LG SST PPHS
M4 x 0.7 x 8LG SST PPHS
M3.5 x 0.6 x 12LG PPHS
FAST BLOW FUSE
16/3 HIGH TEMP SHIELDED SILICONE ELEC CABLE
8-18 x 6LG THREAD FORMING SST PPHS
GROUND WIRE ASSEMBLY

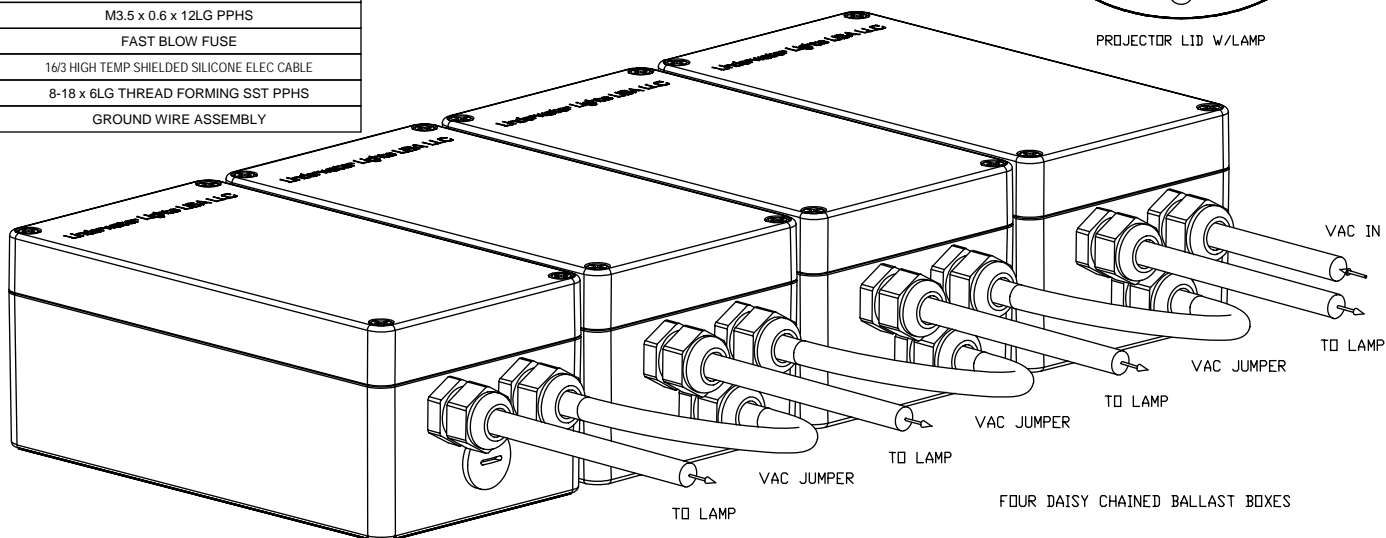
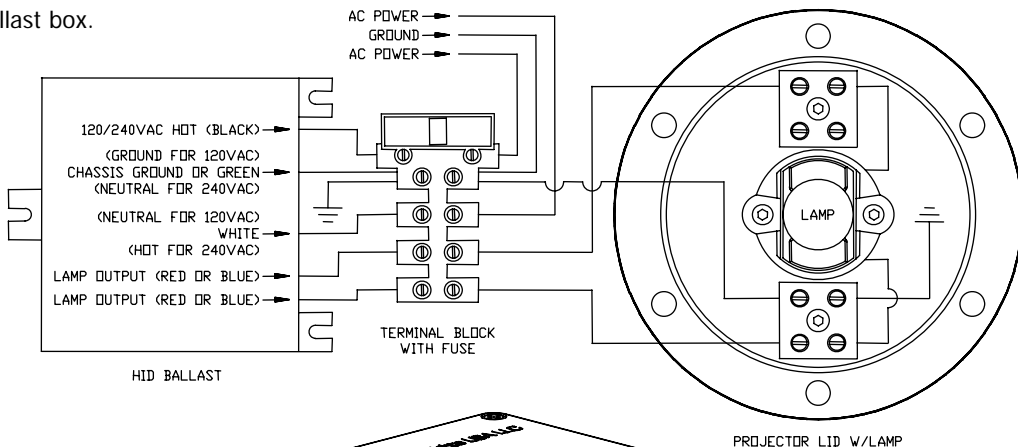

Underwater Lights USA, LLC
277 SW 33rd Court
Fort Lauderdale, FL 33315 USA
Phone: 1-954-760-4447
Fax: 1-954-525-3261
Internet: www.seavision.com
Email: sales@seavision.com



DOC:092005-8W

Underwater Lights Europe Sarl
Résidence L'Hippocampe: 19, Avenue Thiers
06600 Antibes, France
Phone: 33-(0)-4-97-21-02-96
Fax: 33-(0)-4-97-21-10-96
Internet: www.seavision.com
Email: sales@seavisioneurope.com