

SV14 Light

120VAC/150W
240VAC/150W



Introduction:

Congratulations on the purchase of your new weld-in light for **STEEL** hulled vessels. Underwater Lights® USA, LLC takes pride in providing well designed, high quality and thoroughly tested lights that allow you to “enhance your boating experience”. These lights can be installed in your vessel for aesthetics, to attract fish, for security and safety.

General Operating Information:

The 150W, HID, gas discharge lamp used in this light is not an instant re-strike lamp. This means that it must be allowed to cool for approximately 10 to 20 minutes after being shut off before being restarted. HID lamps generally require approximately 2 minutes to reach full brightness and should be left on for a minimum of 10 minutes. Failure to do so may cause the lamp to flicker when it is turned on the next time.

The light can be operated for a brief period of time when the vessel is out of the water, but, it is crucial that the vessel is in the water to ensure proper lamp cooling, however, the light can be operated while the vessel is underway.

Depending upon water clarity conditions, the light beam can reach up to 30 meters (100 feet).

General Safety Information:

This light must be welded into a STEEL hulled vessel in accordance with common ship building practices.

Never try to install or remove this light while the vessel is in the water.

High temperature silicone electrical cable must be used between the light and the ballast, standard ships cable can be used from the A/C power source to the ballast.

Upon proper installation, this light will become part of the vessels grounding and cathodic protection system.

Always disconnect and lock-out power before working on light.

The light should be inspected for moisture every six months.

The light electrical cabling and ballast box should be visually inspected for proper operating condition every six months.

Marine growth should be removed from the glass using a soft brush to allow both heat and illumination to exit the light.

Technical Specifications:

Lamp = 150 Watt - Metal halide - 12,000 Lumens - 7500 Kelvin color temperature - Approximately 3,000 hours life

Glass = Borosilicate glass - 12.7mm (0.5”) thick - 58mm (2.3”) diameter net aperture

Light Common Body Dimensions = 110mm (4.33”) diameter x 180mm (7.0”) long

Smallest Front Flange Dimensions = 100mm (3.94”) diameter x 25mm (0.98”) long

Largest Front Flange Dimensions = 140mm (5.51”) diameter x 213mm (8.39”) long

Construction = Stainless steel - Black anodized marine aluminum alloy

Power supply = 120VAC 50/60Hz input, 1.33 Amps - Minimum operating temperature -30°C (-22°F)

OR

Power supply = 240VAC 50/60Hz input, 0.59 Amps - Minimum operating temperature -30°C (-22°F)

Troubleshooting:

Please contact our technical support staff in Florida at 1-954-760-4447, Monday to Friday from 8:00 am to 5:00 pm EST.

Warranty:

Underwater Lights® USA, LLC warrants this light to be free from defects in workmanship and materials for a period of two years from the date of original purchase (except lamps). Further, misuse, abuse, improper installation, neglect, improper shipping, damage caused by disasters such as fire, flood and lightning, unauthorized repair or modifications will void said warranty. Should your light prove defective during the warranty period, promptly contact Underwater Lights® USA, LLC for an RMA number and then return the light freight prepaid with the RMA number clearly marked on the outside of the shipping container.

Underwater Lights USA, LLC
277 SW 33rd Court
Fort Lauderdale, FL 33315 USA
Phone: 1-954-760-4447
Fax: 1-954-525-3261
Internet: www.seavision.com
Email: sales@seavision.com



DOC:071405-14W

Underwater Lights Europe Sarl
Résidence L'Hippocampe: 19, Avenue Thiers
06600 Antibes, France
Phone: 33-(0)-4-97-21-02-96
Fax: 33-(0)-4-97-21-10-96
Internet: www.seavision.com
Email: sales@seavisioneurope.com

SV14 Light

120VAC/150W
240VAC/150W



Installation:

This light should be installed at least 250-300mm (10-12") below the water line by qualified/approved personnel using proper tools, welding procedures and materials. An access area of at least 75mm (3") should be left behind the light for lamp servicing and general ventilation.

After selecting a location, cut an appropriate sized hole through the vessel hull. Note: Hole size will be defined by the specific weld-in Front Flange (18) that came with the light. Caution! Check that no electrical wiring, fuel lines, oil lines, water lines etc., pass near or through the intended hole location.

Place the supplied Front Flange (18) into said hole and following common ship building practices, permanently weld-in place. Note: Leave the factory installed block-off disk and protective cap on the supplied Front Flange (18) until final light assembly.

Final light assembly - Remove Front Flange (18) block-off disk, protective cap and clean all surfaces. Install two Glass Gaskets (7) (one gasket on either side of glass) Glass (6) and Glass Retaining Ring (3) using six fasteners (14) tightened in a criss-cross pattern to 9 Nm (7 ft/lbs) using a 5mm allen wrench. Screw the Connecting Ring (2) with attached Main Body (1) onto the Front Flange (18) and tighten to 40 Nm (30 ft/lbs). Note: Apply anti-seize compound to Connecting Ring (2) threads. After making proper electrical connections (see ballast manual), attach the Projector Lid (5) to the Main Body (1) using six Nuts (17) tightened to 2 Nm (1.5 ft/lbs). Note: Upon completing light installation, it is highly recommended that the Front Flange (18) be coated with antifouling paint.

Serviceable Parts:

Lamp replacement is done by removing six Nuts (17), removing the Projector Lid (5), pulling the Lamp (11) out of the Lamp Socket (10), pushing a new Lamp (11) into the Lamp Socket (10) and then reversing said procedure. Note: Tighten the six Nuts (17) to 2 Nm (1.5 ft/lbs). Caution! Ensure that the new lamp is clean and free of dust, dirt, grease, oil, water and finger prints.

Glass (6) replacement is done by removing six Nuts (17), Projector Lid (5), Connecting Ring (2) with attached Main Body (1), six fasteners (14), Glass Retaining Ring (3) and Glass Gaskets (7) while the boat is out of the water. Upon thoroughly cleaning all surfaces, reverse said procedure to assemble the new Glass (6) and Glass Gaskets (7). Note: Tighten the six fasteners (14) in a criss-cross pattern to 9 Nm (7 ft/lbs) using a 5mm allen wrench.

BALLOON	DESCRIPTION
1	MAIN BODY
2	CONNECTING RING
3	GLASS RETAINING RING
4	REFLECTOR
5	PROJECTOR LID
6	GLASS
7	GLASS GASKET
8	CONNECTING RING GASKET
9	PROJECTOR LID O-RING
10	LAMP SOCKET
11	LAMP, 150 WATT
12	PORCELAIN TERMINAL BLOCK
13	CABLE STRAIN RELIEF
14	M6 x 1.0 x 14LG SST SHCS
15	M4 x 0.7 x 16LG SST SHCS
16	M6 x 1.0 x 25LG SST SET SCREW
17	M6 x 1.0 SST HEX LOCKNUT
18	CALL TECHNICAL SUPPORT FOR APPROPRIATE FRONT FLANGE

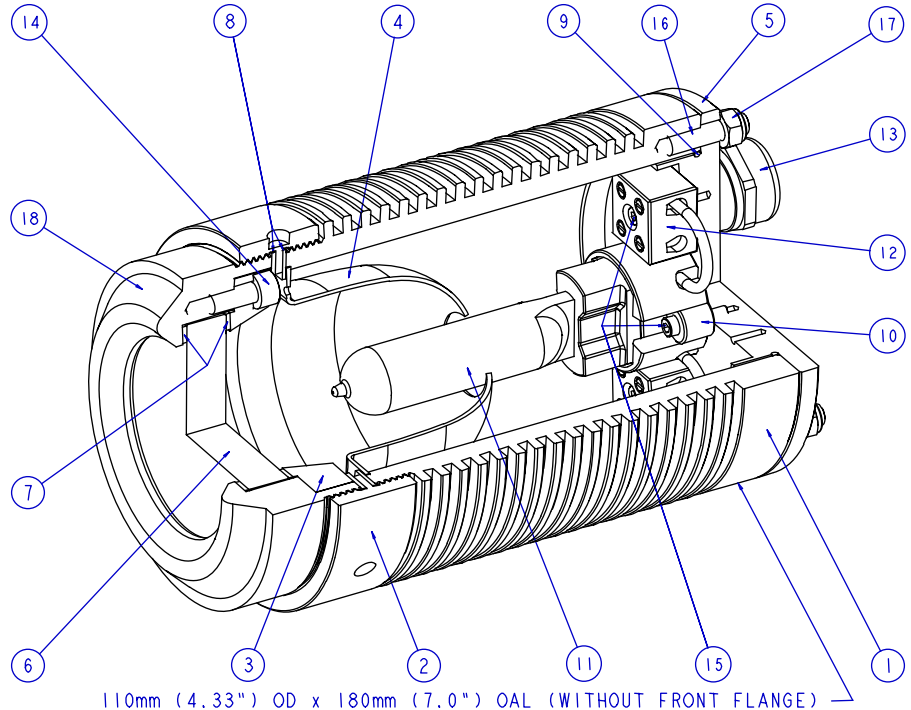

Underwater Lights USA, LLC
277 SW 33rd Court
Fort Lauderdale, FL 33315 USA
Phone: 1-954-760-4447
Fax: 1-954-525-3261
Internet: www.seavision.com
Email: sales@seavision.com



DOC:071405-14W

Underwater Lights Europe Sarl
Résidence L'Hippocampe: 19, Avenue Thiers
06600 Antibes, France
Phone: 33-(0)-4-97-21-02-96
Fax: 33-(0)-4-97-21-10-96
Internet: www.seavision.com
Email: sales@seavisioneurope.com

SV14 Light

120VAC/150W
240VAC/150W



Weld-in Front Flange Selection for **STEEL** Hulled Vessels

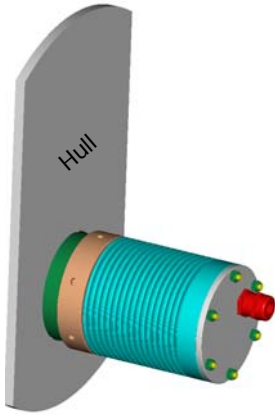

*Light with 0° to 10°
SS Front Flange
(14020)*

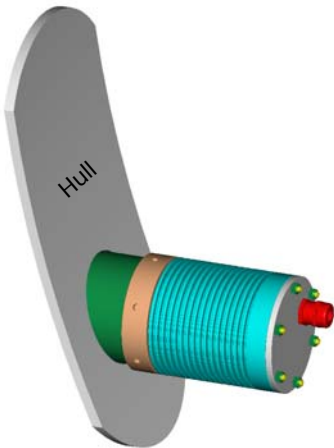
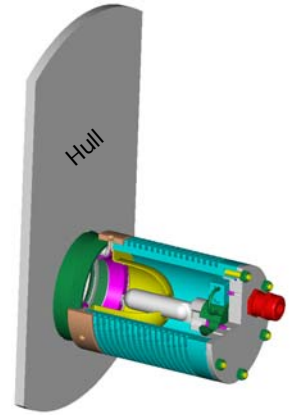

*Light with 10° to 24°
SS Front Flange
(14025)*

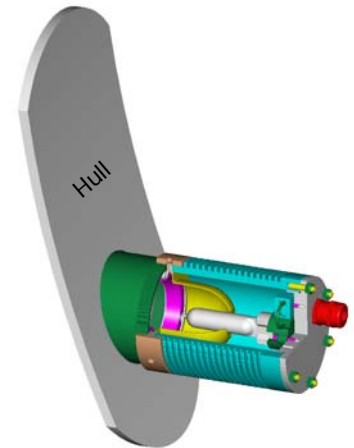

Underwater Lights USA, LLC
277 SW 33rd Court
Fort Lauderdale, FL 33315 USA
Phone: 1-954-760-4447
Fax: 1-954-525-3261
Internet: www.seavision.com
Email: sales@seavision.com



DOC:071405-14W

Underwater Lights Europe Sarl
Résidence L'Hippocampe: 19, Avenue Thiers
06600 Antibes, France
Phone: 33-(0)-4-97-21-02-96
Fax: 33-(0)-4-97-21-10-96
Internet: www.seavision.com
Email: sales@seavisioneurope.com

Weld-in Front Flange Selection for **STEEL** Hulled Vessels

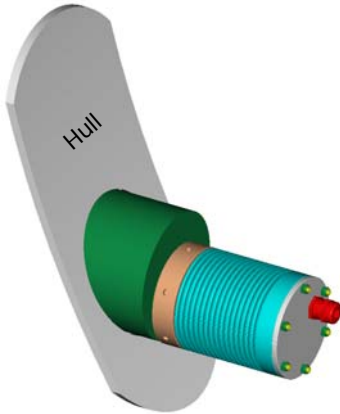

*Light with 24° to 38°
SS Front Flange
(14030)*

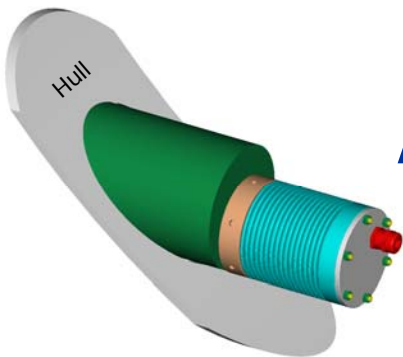
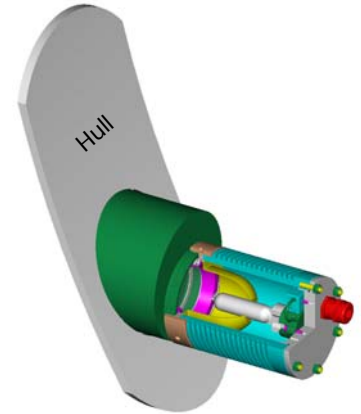

*Light with 38° to 50°
SS Front Flange
(14035)*

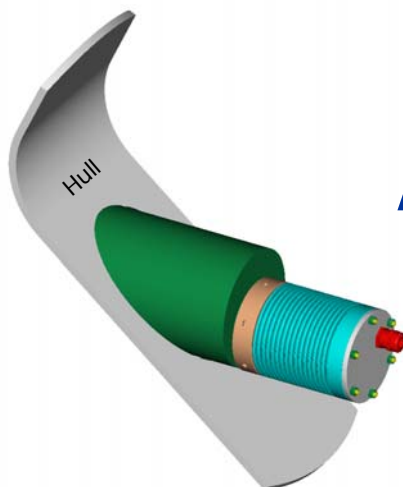
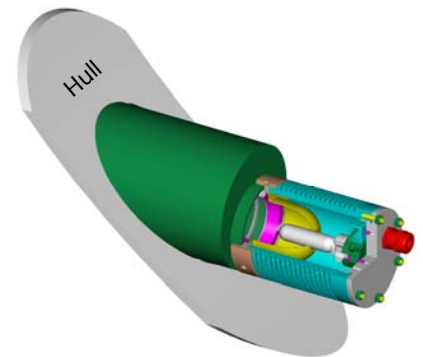

*Light with 38° to 50°
SS Front Flange
(in hull bottom)*

