

DV29 Light

12VDC/100W



Introduction:

Congratulations on the purchase of your new deck light. Underwater Lights® USA, LLC takes pride in providing well designed, high quality and thoroughly tested lights that allow you to “enhance your boating experience”. These lights can be installed in your vessel for aesthetics, security and safety.

General Operating Information:

The commercial grade Halogen lamp used in this light will provide robust and reliable operation under normal operating conditions.

General Safety Information:

This light is intended for vessel exterior (rain or indirect water spray) lighting applications.

Always disconnect and lock-out power before working on light.

Technical Specifications:

Lamp = 100 Watt - Halogen - 3000 Kelvin color temperature - Approximately 3,000 hours life

Glass = Clear or frosted borosilicate glass - 3.2mm (0.125”) thick - 116mm (4.6”) diameter net aperture

Dimensions = 160mm (6.3”) diameter x 136mm (5.35”) long - 1857 grams (4 lbs) - Fits through a 125mm (4.9”) diameter hole

Construction = Stainless steel - Black anodized marine aluminum alloy

Power supply = 12VDC / AC - 8 Amps - Minimum operating temperature -30°C (-22°F)

Troubleshooting:

Please contact our technical support staff in Florida at 1-954-760-4447, Monday to Friday from 8:00 am to 5:00 pm EST.

Warranty:

Underwater Lights® USA, LLC warrants this light to be free from defects in workmanship and materials for a period of one year from the date of original purchase (except lamps). Further, misuse, abuse, improper installation, neglect, improper shipping, damage caused by disasters such as fire, flood and lightning, unauthorized repair or modifications will void said warranty. Should your light prove defective during the warranty period, promptly contact Underwater Lights® USA, LLC for an RMA number and then return the light freight prepaid with the RMA number clearly marked on the outside of the shipping container.

Underwater Lights USA, LLC
277 SW 33rd Court
Fort Lauderdale, FL 33315 USA
Phone: 1-954-760-4447
Fax: 1-954-525-3261
Internet: www.seavision.com
Email: sales@seavision.com



DOC:031406-2W

Underwater Lights Europe Sarl
Résidence L'Hippocampe: 19, Avenue Thiers
06600 Antibes, France
Phone: 33-(0)-4-97-21-02-96
Fax: 33-(0)-4-97-21-10-96
Internet: www.seavision.com
Email: sales@seavisioneurope.com

DV29 Light

12VDC/100W



Installation:

After selecting a flat surface, cut a 125mm (4.9") diameter hole through said surface at the desired location. Caution! Check that no electrical wiring, fuel lines, oil lines, water lines etc., pass near or through the intended hole location.

Unscrew Front Flange (1) or remove Front Flange (16) with Screws (17) from the Main Body (3) and remove six supplied Phillips Flat Head Screws (12). Place Main Body (3) with Body Gasket (9) through above hole and secure using six Phillips Flat Head Screws (12). Note: Depending upon installation surface material, six drilled pilot holes may be required. Screw Front Flange (1) or replace Front Flange (16) with Screws (17) onto the Main Body (3) accordingly. Note: Optional stainless steel or aluminum flush mount weld in adapters are available for this light.

Connect the BLUE wire lead to a switched and fused power source and connect the BROWN wire lead to a good ground.

Serviceable Parts:

Lamp replacement is done by unscrewing the Front Flange (1) or removing the Front Flange (16) with Screws (17) from the Main Body (3), removing the Lamp Spring Clip (7) pulling the old Lamp (15) out of the Swivel Cone (4), disconnecting/connecting two electrical leads, inserting the new Lamp (15) into the Swivel Cone (4), replacing the Lamp Spring Clip (7) then screwing the Front Flange (1) or replacing the Front Flange (16) with Screws (17) onto the Main Body (3) accordingly. Caution! Ensure that the new lamp is clean and free of dust, dirt, grease, oil, water and finger prints. Additionally, the Glass (2) is not field serviceable on this light because it is permanently bonded to Front Flange (1) or (16).

BALLOON	DESCRIPTION
1	THREADED ON FRONT FLANGE, STAINLESS STEEL, MIRROR FINISH*
2	GLASS, CLEAR*
3	MAIN BODY, STAINLESS STEEL*
4	SWIVEL CONE
5	SWIVEL CUP
6	SWIVEL SPRING
7	LAMP SPRING CLIP
8	LAMP COVER
9	BODY GASKET
10	INTERNAL RETAINING RING
11	FRONT FLANGE O-RING
12	No. 10 x 3/4" LG STAINLESS STEEL PHILLIPS FLAT HEAD SCREW
13	CABLE STRAIN RELIEF
14	CABLE STRAIN RELIEF LOCK NUT
15	LAMP, 100 WATT, 24° BEAM ANGLE, 12VDC*
16	SCREWED ON FRONT FLANGE, STAINLESS STEEL, MIRROR FINISH*
17	M5 x 0.8 x 8 LG STAINLESS STEEL SOCKET FLAT HEAD SCREW

*PLEASE CALL FOR OTHER LIGHT COMPONENT CONFIGURATIONS

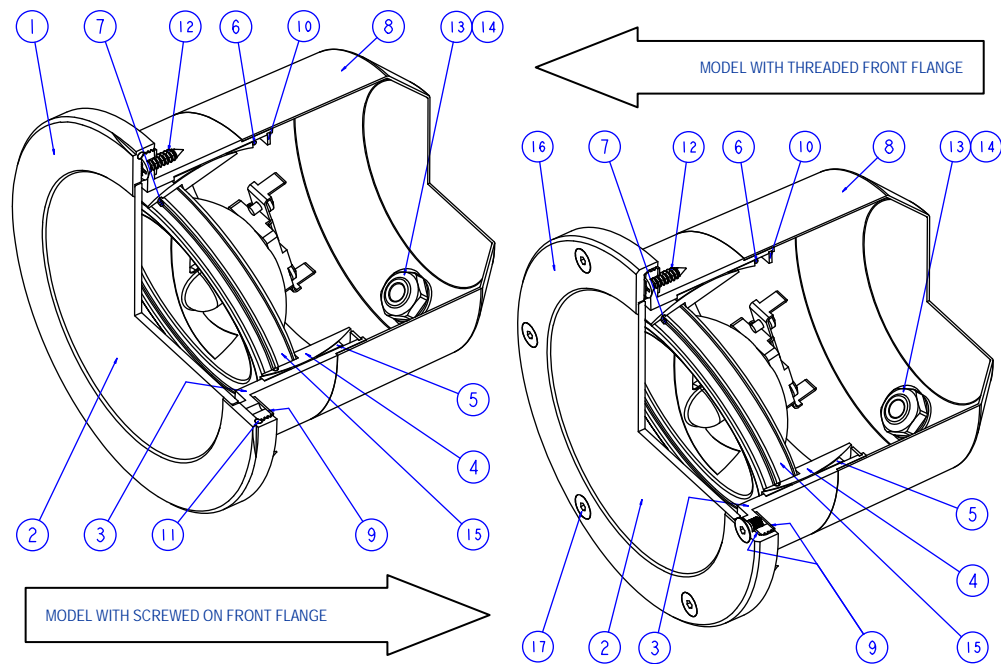

Underwater Lights USA, LLC
 277 SW 33rd Court
 Fort Lauderdale, FL 33315 USA
 Phone: 1-954-760-4447
 Fax: 1-954-525-3261
 Internet: www.seavision.com
 Email: sales@seavision.com



DOC:031406-2W

Underwater Lights Europe Sarl
 Résidence L'Hippocampe: 19, Avenue Thiers
 06600 Antibes, France
 Phone: 33-(0)-4-97-21-02-96
 Fax: 33-(0)-4-97-21-10-96
 Internet: www.seavision.com
 Email: sales@seavisioneurope.com