

DV28 Light, 12VDC LED Array



Introduction:

Congratulations on the purchase of your new deck light. Underwater Lights® USA, LLC takes pride in providing well designed, high quality and thoroughly tested lights that allow you to “enhance your boating experience”. These lights can be installed in your vessel for aesthetics, security and safety.

General Operating Information:

The commercial grade Light Emitting Diode (LED) technology used in this light will provide robust and reliable operation under normal operating conditions.

General Safety Information:

This light is intended for vessel exterior (rain or indirect water spray) lighting applications.

Always disconnect and lock-out power before working on light.

Technical Specifications:

Light source = Four cool white, warm white, blue or red LED arrays - 10 Watts total - Approximately 10,000 hours life

Glass = Borosilicate glass - 3.2mm (0.125”) thick - 101mm (4”) wide x 46mm (1.8”) high net aperture

Dimensions = 145mm (5.7”) wide x 90mm (3.54”) high x 86mm (3.4”) deep - 542 grams (1.2 lbs)

Mounting = Fits through a 112mm (4.4”) wide x 57mm (2.24”) high oval hole

Construction = Stainless steel - Marine aluminum alloy - White PTFE (Teflon)

Power supply = 12VDC – 0.4 Amps

Troubleshooting:

Please contact our technical support staff in Florida at 1-954-760-4447, Monday to Friday from 8:00 am to 5:00 pm EST.

Warranty:

Underwater Lights® USA, LLC warrants this light to be free from defects in workmanship and materials for a period of one year from the date of original purchase. Further, misuse, abuse, improper installation, neglect, improper shipping, damage caused by disasters such as fire, flood and lightning, unauthorized repair or modifications will void said warranty. Should your light prove defective during the warranty period, promptly contact Underwater Lights® USA, LLC for an RMA number and then return the light freight prepaid with the RMA number clearly marked on the outside of the shipping container.

Underwater Lights USA, LLC
277 SW 33rd Court
Fort Lauderdale, FL 33315 USA
Phone: 1-954-760-4447
Fax: 1-954-525-3261
Internet: www.seavision.com
Email: sales@seavision.com



DOC:022806-4W

Underwater Lights Europe Sarl
Résidence L'Hippocampe: 19, Avenue Thiers
06600 Antibes, France
Phone: 33-(0)-4-97-21-02-96
Fax: 33-(0)-4-97-21-10-96
Internet: www.seavision.com
Email: sales@seavisioneurope.com

DV28 Light, 12VDC LED Array



Installation:

After selecting a flat surface, cut a 112mm (4.4") wide x 57mm (2.24") high oval hole through said surface at the desired location. Caution! Check that no electrical wiring, fuel lines, oil lines, water lines etc., pass near or through the intended hole location. Remove six Socket Flat Head Screws (11), Front Flange (2) and six supplied Phillips Flat Head Screws (9). Place Main Body (1) with Large Body O-Ring (7) through above oval hole and carefully secure using six Phillips Flat Head Screws (9). Note: Depending upon installation surface material, six small pilot holes may be required. Place Front Flange (2) onto Main Body (1) and secure using six Socket Flat Head Screws (11).

Connect white wire lead to a switched and fused power source. Connect gray wire lead to a good ground.

Serviceable Parts:

LED array assembly replacement is done by removing six Socket Flat Head Screws (11), Front Flange (2), two Socket Head Cap Screws (10), LED Array Mounting Plate (4), disconnecting wire leads and then reversing said procedure to assemble. Additionally, Glass (3) and Front Flange (2) are a permanently bonded assembly.

BALLOON	DESCRIPTION
1	MAIN BODY*
2	FRONT FLANGE, STAINLESS STEEL, MIRROR FINISH*
3	GLASS, CLEAR*
4	LED ARRAY MOUNTING PLATE
5	BACK COVER
6	SMALL BODY O-RING
7	LARGE BODY O-RING
8	M5 x 0.8 STAINLESS STEEL HEX NUT
9	No. 8 x 3/4" LG STAINLESS STEEL PHILLIPS FLAT HEAD SCREW
10	M3 x 0.5 x 12 LG STAINLESS STEEL SOCKET HEAD CAP SCREW
11	M5 x 0.8 x 8 LG STAINLESS STEEL SOCKET FLAT HEAD SCREW
12	M3 x 0.5 x 12 LG STAINLESS STEEL PHILLIPS PAN HEAD SCREW
13	CABLE STRAIN RELIEF
14	WHITE LED ARRAY ASSEMBLY, 12VDC* BLUE LED ARRAY ASSEMBLY, 12VDC* RED LED ARRAY ASSEMBLY, 12VDC*
15	ALUMINUM BLIND RIVET
*PLEASE CALL FOR OTHER LIGHT COMPONENT CONFIGURATIONS	

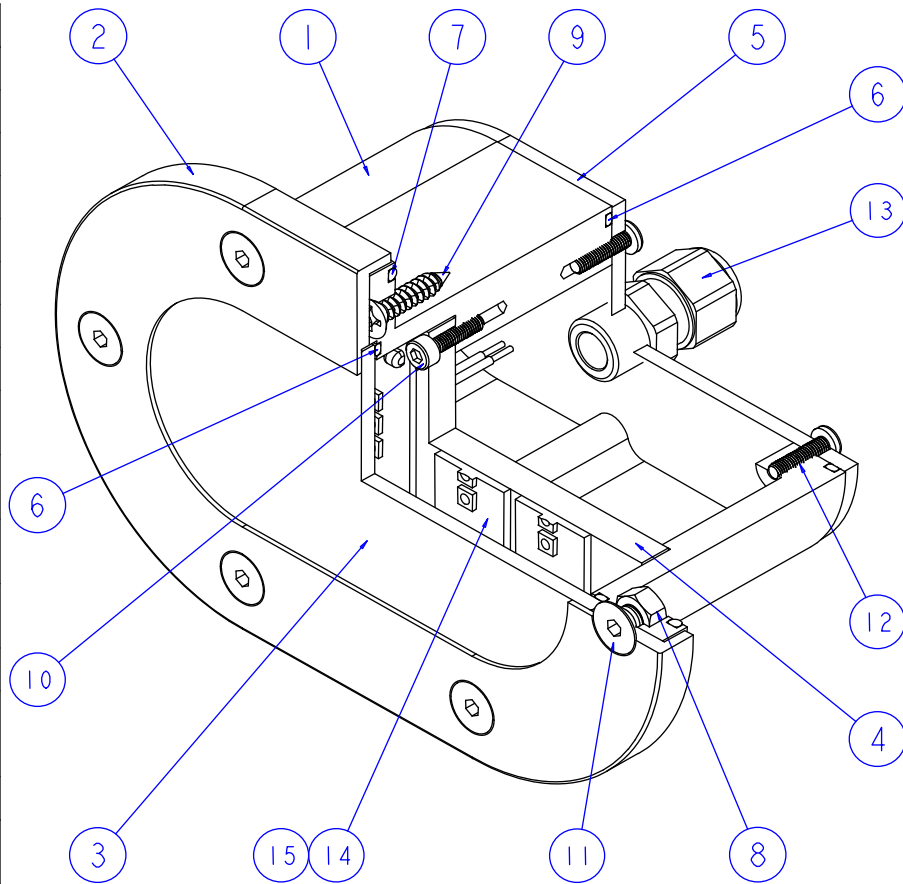

Underwater Lights USA, LLC
 277 SW 33rd Court
 Fort Lauderdale, FL 33315 USA
 Phone: 1-954-760-4447
 Fax: 1-954-525-3261
 Internet: www.seavision.com
 Email: sales@seavision.com



DOC:022806-4W

Underwater Lights Europe Sarl
 Résidence L'Hippocampe: 19, Avenue Thiers
 06600 Antibes, France
 Phone: 33-(0)-4-97-21-02-96
 Fax: 33-(0)-4-97-21-10-96
 Internet: www.seavision.com
 Email: sales@seavisioneurope.com