

SV37 Plasma



The Sea Vision SV37 Plasma weld in model for aluminum or steel hulls can be installed in the transom or the hull, it utilizes a light emitting plasma (LEP) light source and 110 or 230 volt AC power. LEPs are the next generation of high intensity lighting. Sea Vision has adapted this technology to become the successor to their metal halide line of underwater lighting for mega yachts. The lights can be welded at adjustable angles to suit all hull shapes. The hull shape and positioning will dictate the angle of the light you require, angles available are 0 to 50 degree.



SV37 technical specifications

Application for:	Aluminum or Steel hulls
Lamp:	Light Emitting Plasma
Life length:	approx. 30,000 hours
Lumens:	23,000
Kelvin color temp:	5750
Glass lens:	Borosilicate glass
Thickness:	20mm / 0.79"
Power supply:	100 – 240 VAC, 4.0 – 1.5 Amps,
Casing material:	Aluminum 5086 / Stainless Steel 316L

Angles available:	Flush 30 degree 24 – 38 degree 38 – 50 degree
-------------------	--

Code:	SV37 Plasma
-------	-------------

Installation:	Recommended at least 10" (250mm) below the light load waterline and between 9 and 16 feet (3 - 5 meters) apart.
---------------	---

This is a guideline only, for specific requirements please contact us.

Note: All information is subject to change without prior notice, please confirm details prior to ordering.

SV37 Light

120VAC-240VAC
PLASMA 600



Introduction:

Congratulations on the purchase of your new weld-in light for **ALUMINUM** hulled vessels. Underwater Lights® USA, LLC takes pride in providing well designed, high quality and thoroughly tested lights that allow you to “enhance your boating experience”. These lights can be installed in your vessel for aesthetics, to attract fish, for security and safety.

General Operating Information:

The emitter module in this product utilizes a rapid start and re-strike plasma light source. This means that it must be allowed to cool for approximately 2 minutes after being shut off before being restarted. Failure to do so may cause a diminished light output.

The light can be operated for a brief period of time when the vessel is out of the water, but, it is crucial that the vessel is in the water to ensure proper emitter module cooling, however, the light can be operated while the vessel is underway.

Depending upon water clarity conditions, the light beam can reach up to 40 meters (131 feet).

General Safety Information:

This light must be welded into a ALUMINUM hulled vessel in accordance with common ship building practices.

Never try to install or remove the glass lens while the vessel is in the water.

Supplied RF cable must be used between the emitter module and emitter driver.

Upon proper installation, this light will become part of the vessels grounding and cathodic protection system.

Always disconnect and lock-out power before working on light.

The light should be inspected for moisture every six months.

Electrical cabling for the emitter module, emitter driver and emitter driver power supply should be visually inspected for proper operating condition every six months.

Marine growth should be removed from the glass using a soft brush to allow both heat and illumination to exit the light.

Technical Specifications:

Light Source = RF plasma - 23,000 Lumens - 5750 Kelvin color temperature - Approximately 30,000 hrs life - 60 second start time

Glass = Borosilicate glass - 20mm (0.79”) thick - 86mm (3.39”) diameter net aperture

Light Common Body Dimensions = 106mm (4.17”) diameter x 101mm (3.9”) long

Smallest Front Flange Dimensions = 175mm (6.89”) diameter x 49mm (1.9”) long

Largest Front Flange Dimensions = 226mm (8.89”) diameter x 359mm (14.1”) long

Construction = Bright dip anodized marine aluminum alloy - Black anodized marine aluminum alloy

Power Source = Only use matching Underwater Lights USA, LLC emitter driver

Troubleshooting:

Please contact our technical support staff in Florida at 1-954-760-4447, Monday to Friday from 8:00 am to 5:00 pm EST.

Warranty:

Underwater Lights® USA, LLC warrants this light to be free from defects in workmanship and materials for a period of two years from the date of original purchase (except emitter module). Further, misuse, abuse, improper installation, neglect, improper shipping, damage caused by disasters such as fire, flood and lightning, unauthorized repair or modifications will void said warranty. Should your light prove defective during the warranty period, promptly contact Underwater Lights USA, LLC for an RMA number and then return the light freight prepaid with the RMA number clearly marked on the outside of the shipping container.

Underwater Lights USA, LLC
1881 W State Road 84, Bay 102
Fort Lauderdale, FL 33315 USA
Phone: 1-954-760-4447
Fax: 1-954-525-3261
Internet: www.seavision.com
Email: sales@seavision.com

DOC:103009-2

Underwater Lights Europe Sarl
Résidence L'Hippocampe: 19, Avenue Thiers
06600 Antibes, France
Phone: 33-(0)-4-97-21-02-96
Fax: 33-(0)-4-97-21-10-96
Internet: www.seavision.com
Email: sales@seavisioneurope.com

SV37 Light

120VAC-240VAC
PLASMA 600



Installation:

This light should be installed at minimum 250-300mm (10-12") below the light load water line by qualified/approved personnel using proper tools, welding procedures and materials. An access area of at least 75mm (3") should be left behind the light for lamp servicing and general ventilation.

After selecting a location, cut an appropriate sized hole through the vessel hull. Note: Hole size will be defined by the specific weld-in Front Flange (12) that came with the light. Caution! Check that no electrical wiring, fuel lines, oil lines, water lines etc., pass near or through the intended hole location.

Place the supplied Front Flange (12) into said hole and following common ship building practices, permanently weld-in place. Note: Leave the factory installed block-off disk on the supplied Front Flange (12) until final light assembly.

Final light assembly - Remove Front Flange (12) block-off disk and clean all surfaces. Install two Glass Gaskets (4) [one gasket on either side of glass], Glass (3), Retaining Flange O-ring (7) and Glass Retaining Flange (1) using eight fasteners (9) tightened in a criss-cross pattern to 9 Nm (7 ft/lbs) using a 5mm allen wrench. Note: Orient Glass Retaining Flange (1) on Front Flange (12) such that Emitter Module (11) glass bulb "centerline axis" is in the horizontal position. Orient and install Reflector (2) into Glass Retaining Flange (1). Install Emitter Outer Gasket (6) on Emitter Module (11). Orient and install Emitter Gasket (5) and Emitter Module (11) into Glass Retaining Flange (1) and secure with four fasteners (8) evenly hand tightened using a phillips screwdriver. Caution! Use care when handling Emitter Module (11) to avoid breaking central glass bulb. Carefully connect threaded RF cable from Emitter Driver (not shown) to Emitter Module (11). Note: Upon completing light installation, it is highly recommended that Front Flange (12) be coated with antifouling paint.

Serviceable Parts:

Emitter Module (11) replacement is done by disconnecting threaded RF cable from Emitter Driver (not shown), removing four fasteners (8), carefully removing old Emitter Module (11) and then reversing said procedure. Note: Evenly hand tighten four fasteners (8) using a phillips screwdriver. Caution! Ensure that new Emitter Module (11) central glass bulb is clean and free of dust, dirt, grease, oil, water and finger prints.

Glass (3) replacement is done by removing eight fasteners (9), Glass Retaining Flange (1) with attached components and Glass Gaskets (4) while the boat is out of the water. Upon thoroughly cleaning all surfaces, reverse said procedure to assemble new Glass (3) and Glass Gaskets (4). Note: Tighten fasteners (9) in a criss-cross pattern to 9 Nm (7 ft/lbs) using a 5mm allen wrench.

MODEL E14_10A33, 120VAC-240VAC		
BALLOON	PART	DESCRIPTION
1	37602	GLASS RETAINING FLANGE
2	37604	REFLECTOR
3	37007	GLASS
4	37008	GLASS GASKET
5	37305	EMITTER GASKET
6	37306	EMITTER OUTER GASKET
7	37010	RETAINING FLANGE O-RING
8	37307	M5 x 0.8 x 12LG SST PPHS
9	37017	M6 x 1.0 x 25LG SST SHCS
10	37308	4.0 DIA x 10LG SST DOWEL PIN
11	37309	EMITTER MODULE
12	N/A	CALL TECHNICAL SUPPORT FOR APPROPRIATE FRONT FLANGE

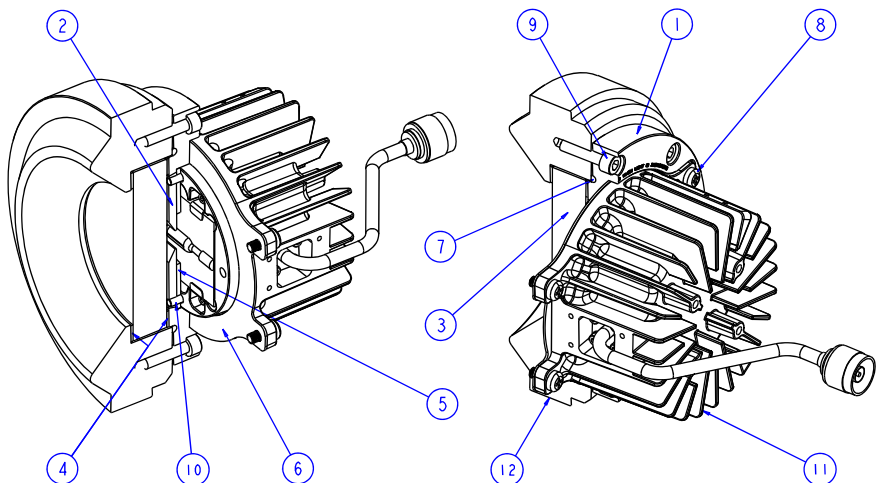

Underwater Lights USA, LLC
1881 W State Road 84, Bay 102
Fort Lauderdale, FL 33315 USA
Phone: 1-954-760-4447
Fax: 1-954-525-3261
Internet: www.seavision.com
Email: sales@seavision.com

DOC:103009-2

Underwater Lights Europe Sarl
Résidence L'Hippocampe: 19, Avenue Thiers
06600 Antibes, France
Phone: 33-(0)-4-97-21-02-96
Fax: 33-(0)-4-97-21-10-96
Internet: www.seavision.com
Email: sales@seavisioneurope.com

SV37 Light

120VAC-240VAC
PLASMA 600



Introduction:

Congratulations on the purchase of your new weld-in light for **STEEL** hulled vessels. Underwater Lights® USA, LLC takes pride in providing well designed, high quality and thoroughly tested lights that allow you to “enhance your boating experience”. These lights can be installed in your vessel for aesthetics, to attract fish, for security and safety.

General Operating Information:

The emitter module in this product utilizes a rapid start and re-strike plasma light source. This means that it must be allowed to cool for approximately 2 minutes after being shut off before being restarted. Failure to do so may cause a diminished light output.

The light can be operated for a brief period of time when the vessel is out of the water, but, it is crucial that the vessel is in the water to ensure proper emitter module cooling, however, the light can be operated while the vessel is underway.

Depending upon water clarity conditions, the light beam can reach up to 40 meters (131 feet).

General Safety Information:

This light must be welded into a STEEL hulled vessel in accordance with common ship building practices.

Never try to install or remove the glass lens while the vessel is in the water.

Supplied RF cable must be used between the emitter module and emitter driver.

Upon proper installation, this light will become part of the vessels grounding and cathodic protection system.

Always disconnect and lock-out power before working on light.

The light should be inspected for moisture every six months.

Electrical cabling for the emitter module, emitter driver and emitter driver power supply should be visually inspected for proper operating condition every six months.

Marine growth should be removed from the glass using a soft brush to allow both heat and illumination to exit the light.

Technical Specifications:

Light Source = RF plasma - 23,000 Lumens - 5750 Kelvin color temperature - Approximately 30,000 hrs life - 60 second start time

Glass = Borosilicate glass - 20mm (0.79”) thick - 86mm (3.39”) diameter net aperture

Light Common Body Dimensions = 106mm (4.17”) diameter x 101mm (3.9”) long

Smallest Front Flange Dimensions = 175mm (6.89”) diameter x 49mm (1.9”) long

Largest Front Flange Dimensions = 226mm (8.89”) diameter x 359mm (14.1”) long

Construction = Stainless steel - Black anodized marine aluminum alloy

Power Source = Only use matching Underwater Lights USA, LLC emitter driver

Troubleshooting:

Please contact our technical support staff in Florida at 1-954-760-4447, Monday to Friday from 8:00 am to 5:00 pm EST.

Warranty:

Underwater Lights® USA, LLC warrants this light to be free from defects in workmanship and materials for a period of two years from the date of original purchase (except emitter module). Further, misuse, abuse, improper installation, neglect, improper shipping, damage caused by disasters such as fire, flood and lightning, unauthorized repair or modifications will void said warranty. Should your light prove defective during the warranty period, promptly contact Underwater Lights USA, LLC for an RMA number and then return the light freight prepaid with the RMA number clearly marked on the outside of the shipping container.

Underwater Lights USA, LLC
1881 W State Road 84, Bay 102
Fort Lauderdale, FL 33315 USA
Phone: 1-954-760-4447
Fax: 1-954-525-3261
Internet: www.seavision.com
Email: sales@seavision.com

DOC:102909-2

Underwater Lights Europe Sarl
Résidence L'Hippocampe: 19, Avenue Thiers
06600 Antibes, France
Phone: 33-(0)-4-97-21-02-96
Fax: 33-(0)-4-97-21-10-96
Internet: www.seavision.com
Email: sales@seavisioneurope.com

SV37 Light

120VAC-240VAC
PLASMA 600



Installation:

This light should be installed at minimum 250-300mm (10-12") below the light load water line by qualified/approved personnel using proper tools, welding procedures and materials. An access area of at least 75mm (3") should be left behind the light for lamp servicing and general ventilation.

After selecting a location, cut an appropriate sized hole through the vessel hull. Note: Hole size will be defined by the specific weld-in Front Flange (12) that came with the light. Caution! Check that no electrical wiring, fuel lines, oil lines, water lines etc., pass near or through the intended hole location.

Place the supplied Front Flange (12) into said hole and following common ship building practices, permanently weld-in place. Note: Leave the factory installed block-off disk on the supplied Front Flange (12) until final light assembly.

Final light assembly - Remove Front Flange (12) block-off disk and clean all surfaces. Install two Glass Gaskets (4) [one gasket on either side of glass], Glass (3), Retaining Flange O-ring (7) and Glass Retaining Flange (1) using eight fasteners (9) tightened in a criss-cross pattern to 9 Nm (7 ft/lbs) using a 5mm allen wrench. Note: Orient Glass Retaining Flange (1) on Front Flange (12) such that Emitter Module (11) glass bulb "centerline axis" is in the horizontal position. Orient and install Reflector (2) into Glass Retaining Flange (1). Install Emitter Outer Gasket (6) on Emitter Module (11). Orient and install Emitter Gasket (5) and Emitter Module (11) into Glass Retaining Flange (1) and secure with four fasteners (8) evenly hand tightened using a phillips screwdriver. Caution! Use care when handling Emitter Module (11) to avoid breaking central glass bulb. Carefully connect threaded RF cable from Emitter Driver (not shown) to Emitter Module (11). Note: Upon completing light installation, it is highly recommended that Front Flange (12) be coated with antifouling paint.

Serviceable Parts:

Emitter Module (11) replacement is done by disconnecting threaded RF cable from Emitter Driver (not shown), removing four fasteners (8), carefully removing old Emitter Module (11) and then reversing said procedure. Note: Evenly hand tighten four fasteners (8) using a phillips screwdriver. Caution! Ensure that new Emitter Module (11) central glass bulb is clean and free of dust, dirt, grease, oil, water and finger prints.

Glass (3) replacement is done by removing eight fasteners (9), Glass Retaining Flange (1) with attached components and Glass Gaskets (4) while the boat is out of the water. Upon thoroughly cleaning all surfaces, reverse said procedure to assemble new Glass (3) and Glass Gaskets (4). Note: Tighten fasteners (9) in a criss-cross pattern to 9 Nm (7 ft/lbs) using a 5mm allen wrench.

MODEL E14_12A33, 120VAC-240VAC		
BALLOON	PART	DESCRIPTION
1	37601	GLASS RETAINING FLANGE
2	37603	REFLECTOR
3	37007	GLASS
4	37008	GLASS GASKET
5	37305	EMITTER GASKET
6	37310	EMITTER OUTER GASKET
7	37010	RETAINING FLANGE O-RING
8	37307	M5 x 0.8 x 12LG SST PPHS
9	37017	M6 x 1.0 x 25LG SST SHCS
10	37308	4.0 DIA x 10LG SST DOWEL PIN
11	37309	EMITTER MODULE
12	N/A	CALL TECHNICAL SUPPORT FOR APPROPRIATE FRONT FLANGE

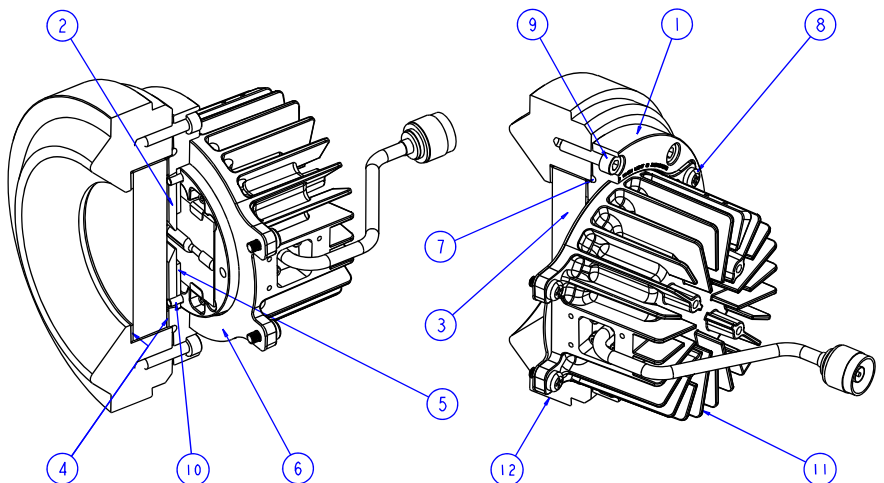

Underwater Lights USA, LLC
1881 W State Road 84, Bay 102
Fort Lauderdale, FL 33315 USA
Phone: 1-954-760-4447
Fax: 1-954-525-3261
Internet: www.seavision.com
Email: sales@seavision.com

DOC:102909-2

Underwater Lights Europe Sarl
Résidence L'Hippocampe: 19, Avenue Thiers
06600 Antibes, France
Phone: 33-(0)-4-97-21-02-96
Fax: 33-(0)-4-97-21-10-96
Internet: www.seavision.com
Email: sales@seavisioneurope.com

SV37 & SV10, Plasma Light Driver Assembly



Introduction:

Congratulations on the purchase of your new driver assembly for your Underwater Lights™ USA, LLC plasma weld-in light. Underwater Lights™ USA, LLC takes pride in providing well designed, high quality and thoroughly tested lights that allow you to “enhance your boating experience”. These lights can be installed in your vessel for aesthetics, to attract fish, for security and safety.

Features Include:

Latest microprocessor control technology to guarantee high levels of performance.

Provides flicker free power to matching plasma weld-in light emitter.

Two industrial grade terminal strips for easy electrical wire lead hook-up.

Industrial grade RF cable from driver to plasma weld-in light emitter can be screwed on and off by hand.

Driver mounted on large heat sink with positive airflow tubeaxial fan to ensure cool operation and long life.

General Safety Information:

This driver assembly is specifically designed for use with matching Underwater Lights USA, LLC brand plasma lights only.

Always ensure that main power is disconnected and locked out before performing driver assembly installation and/or service.

Driver assembly, tubeaxial fan and electrical cabling should be visually inspected for proper operating condition every six months.

Technical Specifications:

Service Life = Approximately 30,000 hours

Overall Dimensions = 395mm (15.55”) long x 177mm (6.97”) wide x 116mm (4.57”) tall - 6.9 kilograms (15.4 pounds)

Construction = Black anodized aluminum alloy - Stainless steel fasteners

Power Source = 28VDC, 9.6 Amps - Ambient operating temperature from -20°C (-4°F) to 52°C (125°F)

Troubleshooting:

Please contact our technical support staff in Florida at 1-954-760-4447, Monday to Friday from 8:00 am to 5:00 pm EST.

Warranty:

Underwater Lights™ USA, LLC warrants this driver assembly to be free from defects in workmanship and materials for a period of two years from the date of original purchase. Further, misuse, abuse, improper installation, neglect, improper shipping, damage caused by disasters such as fire, flood and lightning, unauthorized repair or modifications will void said warranty. Should your driver assembly prove defective during the warranty period, promptly contact Underwater Lights USA, LLC for an RMA number and then return the driver assembly freight prepaid with the RMA number clearly marked on the outside of the shipping container.

SV37 & SV10, Plasma Light Driver Assembly



Installation:

Select a driver assembly mounting location that is in close proximity to and somewhat above the plasma weld-in light. Also, the driver assembly should be placed in an easily accessible, cool, dry and well ventilated area. Note: Whereas the driver assembly can be mounted in any orientation, it is best to have the heat sink fins placed vertical with the round RF cable connector facing down.

Plasma lamp "basic mode" wiring diagram is shown below. Important! Only use marine grade electrical wire. Note: Call technical support for other plasma light modes of operation.

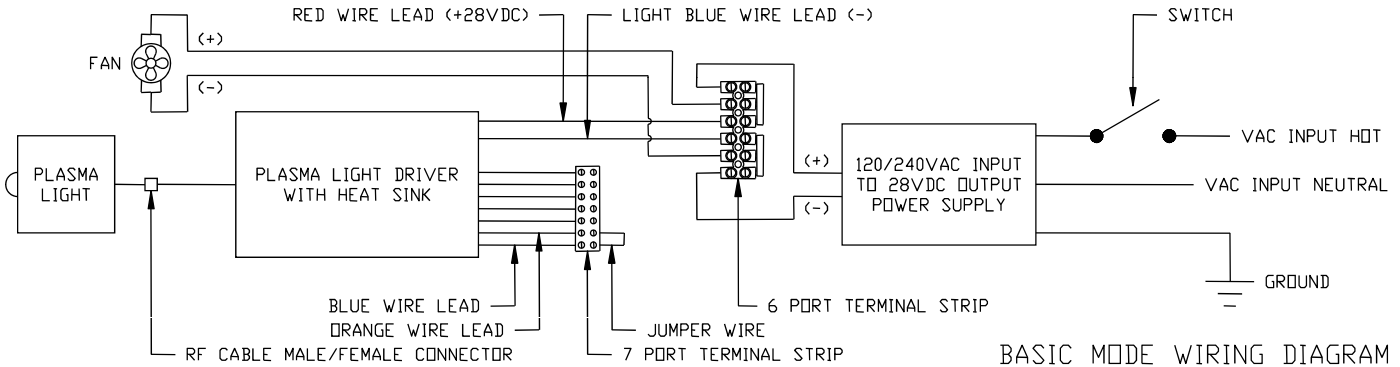

Carefully route supplied RF cable between driver assembly and plasma light then screw large round cable connectors accordingly. Upon double checking all electrical connections, test plasma lamp for proper operation. Caution! Avoid making tight bends and/or passing electrical leads or RF cable over sharp edges/surfaces.

Serviceable Parts:

Driver (5) can be replaced by unscrewing Cable (6), disconnecting Driver (5) wire leads, removing five fasteners (4), carefully removing old Driver (5) and then reversing said procedure. Note: Ensure that Driver (5) to Finned Heat Sink (2) mating surface is free of dust, dirt, grease, oil, water and corrosion. Caution! Driver (5) contains no user serviceable parts, do not disassemble.

MODELS 17J28J27 & 17K28J27		
BALLOON	PART	DESCRIPTION
1	37401	MOUNTING BRACKET
2	37402	FINNED HEAT SINK
3	37403	M6 x 1.0 x 8LG SST PPHS
4	37404	M5 x 0.8 x 16LG SST SHCS
5	37405 37435	DRIVER FOR 37211 EMITTER DRIVER FOR 37309 EMITTER
6	37406 37407 37436 37437	CABLE WITH NO GLANDS FOR 37405 CABLE WITH EMITTER GLAND FOR 37405 CABLE WITH NO GLANDS FOR 37435 CABLE WITH EMITTER GLAND FOR 37435
7	37450	TUBEAXIAL FAN
8	37451	FINGER GUARD
9	37452	M4 x 0.7 x 30LG SST PPHS
10	37453	6-POLE TERMINAL STRIP
11	37454	3-POLE EXTERNAL JUMPER
12	37419	7-POLE TERMINAL STRIP
13	37420	M3 x 0.5 x 12LG SST SHCS

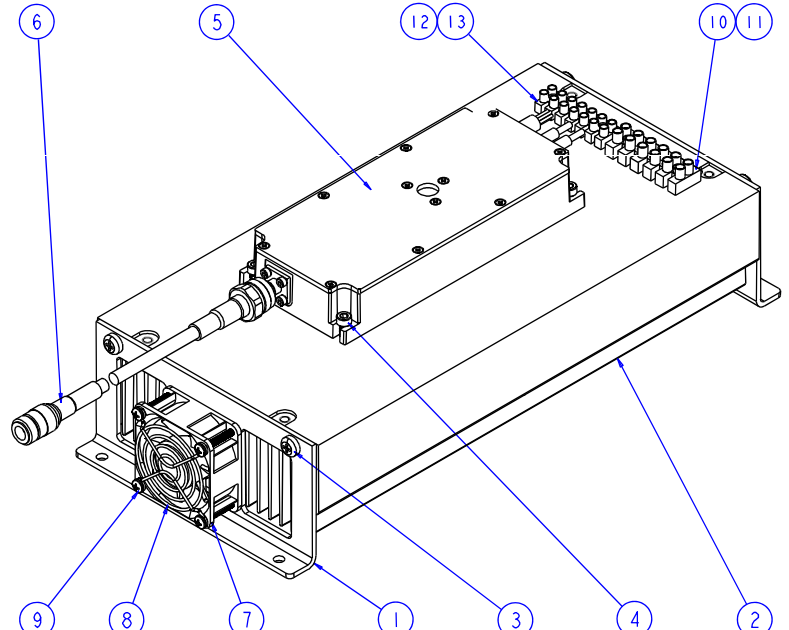

Underwater Lights USA, LLC
1881 W State Road 84, Bay 102
Fort Lauderdale, FL 33315 USA
Phone: 1-954-760-4447
Fax: 1-954-525-3261
Internet: www.seavision.com
Email: sales@seavision.com

DOC:102409-3

Underwater Lights Europe Sarl
Résidence L'Hippocampe: 19, Avenue Thiers
06600 Antibes, France
Phone: 33-(0)-4-97-21-02-96
Fax: 33-(0)-4-97-21-10-96
Internet: www.seavision.com
Email: sales@seavisioneurope.com

SV37 & SV10, Plasma Light Power Supply Box



Introduction:

Congratulations on the purchase of your new power supply box for your Underwater Lights® USA, LLC plasma weld-in light. Underwater Lights® USA, LLC takes pride in providing well designed, high quality and thoroughly tested lights that allow you to “enhance your boating experience”. These lights can be installed in your vessel for aesthetics, to attract fish, for security and safety.

Features Include:

- Universal input with single output industrial grade power source for high level of performance.
- Constant, stable and uniform 28VDC power to matching plasma weld-in light driver.
- Powder coated diecast aluminum enclosure with stainless steel lid fasteners and silicone rubber lid gasket, IP65/NEMA 4X rated.
- One externally accessible pushbutton circuit protector mounted to enclosure lid for power “input” circuit protection.
- One externally accessible pushbutton circuit protector mounted to enclosure lid for power “output” circuit protection.
- One green LED lamp mounted to enclosure lid for “input power on” indication.
- One green LED lamp mounted to enclosure lid for “output power on” indication.
- Internally accessible electrical wiring terminal block with VAC input fuse protection for easy wire lead hook-up.
- Electrical provision for “daisy chaining” of additional LED driver boxes.

General Safety Information:

- This power supply box is specifically designed for use with matching Underwater Lights® USA, LLC brand plasma lights only.
- Always ensure that main power is disconnected and locked out before performing power supply box installation and/or service.
- Power supply box with electrical cabling thereof should be visually inspected for proper operating condition every six months.

Technical Specifications:

- Service Life = Approximately 30,000 hours
- Overall Dimensions = 360mm (14.17”) long x 160mm (6.29”) wide x 91mm (3.58”) tall - 5.3 kilograms (11.7 pounds)
- Construction = Powder coated diecast aluminum - Stainless steel fasteners
- Power Source = 90-305VAC, 3.3-1.6 Amps - Operating temperature from -20°C (-4°F) to 71°C (160°F)

Troubleshooting:

Please contact our technical support staff in Florida at 1-954-760-4447, Monday to Friday from 8:00 am to 5:00 pm EST.

Warranty:

Underwater Lights® USA, LLC warrants this power supply box to be free from defects in workmanship and materials for a period of two years from the date of original purchase. Further, misuse, abuse, improper installation, neglect, improper shipping, damage caused by disasters such as fire, flood and lightning, unauthorized repair or modifications will void said warranty. Should your power supply box prove defective during the warranty period, promptly contact Underwater Lights® USA, LLC for an RMA number and then return the power supply box freight prepaid with RMA number clearly marked on the outside of the shipping container.

Underwater Lights USA, LLC
1881 W State Road 84, Bay 102
Fort Lauderdale, FL 33315 USA
Phone: 1-954-760-4447
Fax: 1-954-525-3261
Internet: www.seavision.com
Email: sales@seavision.com

DOC:102809-3

Underwater Lights Europe Sarl
Résidence L’Hippocampe: 19, Avenue Thiers
06600 Antibes, France
Phone: 33-(0)-4-97-21-02-96
Fax: 33-(0)-4-97-21-10-96
Internet: www.seavision.com
Email: sales@seavisioneurope.com

SV37 & SV10, Plasma Light Power Supply Box



Installation:

Select a mounting location that is in close proximity to and somewhat above the plasma weld-in light driver assembly (or driver box assembly). Also, the power supply box should be placed in an easily accessible, cool, dry and well ventilated area. Note: Whereas the power supply box can be mounted in any orientation, it is best to have the cable glands facing down.

Using marine grade 14/3 cable, run a VAC line into and VDC line out of the power supply box and secure using two cable strain relief connectors. Make electrical connections to fused terminal block and pushbutton circuit protector per wiring diagram below.

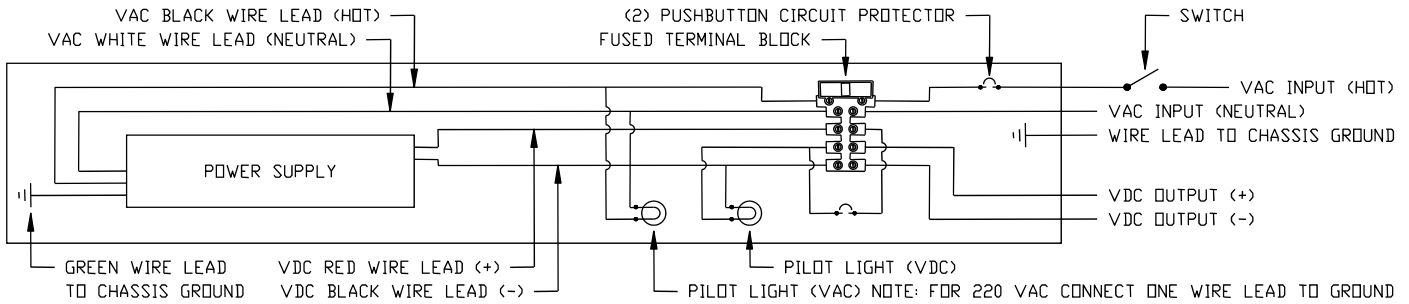

Carefully route electrical cable between power supply box and plasma weld-in light driver assembly (or driver box assembly) accordingly. Upon double checking all electrical connections, test plasma lamp for proper operation. Caution! Avoid making tight bends and/or passing electrical cables over sharp edges/surfaces.

Optional: Using marine grade 14/3 cable, a VAC jumper line can be "daisy chained" to an additional power supply box by replacing the blanking plug with supplied cable strain relief connector. Note: Up to four power supply boxes can be "daisy chained".

Serviceable Parts:

Important! Disconnect and lock out main power first. Upon opening the power supply box by loosening four captive Power Supply Enclosure Lid (2) fasteners, internal components can be serviced by removing and replacing associated fasteners and wiring as needed. Note: Ensure that Power Supply (3) to Power Supply Enclosure Box (1) mating surface is free of dust, dirt, grease, oil, water and corrosion. Caution! Power Supply (3) contains no user serviceable parts, do not disassemble.

MODEL 12G31J99		
BALLOON	PART	DESCRIPTION
1	37444	POWER SUPPLY ENCLOSURE BOX
2	37428	POWER SUPPLY ENCLOSURE LID
3	37445	SINGLE OUTPUT UNIVERSAL POWER SUPPLY
4	37430	No. 8-18 x 1/4" LG THREAD FORMING SST PPHS
5	37431	PUSHBUTTON CIRCUIT PROTECTOR, 5A
6	37421	PUSHBUTTON CIRCUIT PROTECTOR, 15A
7	37422	PROTECTOR RETAINING CLIP
8	37423	PROTECTOR PANEL SEAL BOOT
9	37432	LED PILOT LIGHT, GREEN, 120 VAC
10	37424	LED PILOT LIGHT, GREEN, 28VDC
11	37425	PILOT LIGHT MOUNTING CLIP
12	37426	CABLE STRAIN RELIEF
13	37442	BLANKING PLUG
14	37446	TERMINAL BLOCK MOUNT
15	37447	No. 8-18 x 5/16" LG THREAD FORMING SST PPHS
16	37448	FUSED TERMINAL BLOCK
17	37449	FAST BLOW FUSE
18	37443	M3.5 x 0.6 x 12LG PPHS

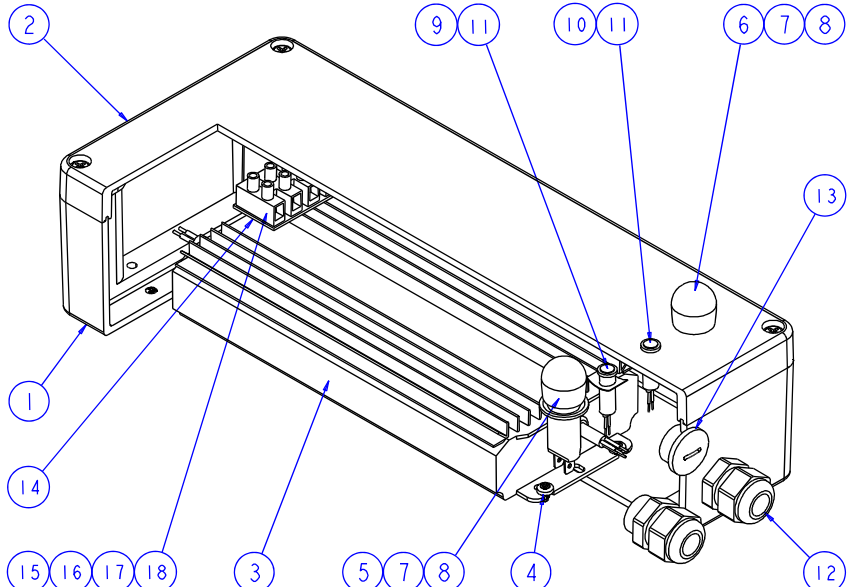

Underwater Lights USA, LLC
1881 W State Road 84, Bay 102
Fort Lauderdale, FL 33315 USA
Phone: 1-954-760-4447
Fax: 1-954-525-3261
Internet: www.seavision.com
Email: sales@seavision.com

DOC:102809-3

Underwater Lights Europe Sarl
Résidence L'Hippocampe: 19, Avenue Thiers
06600 Antibes, France
Phone: 33-(0)-4-97-21-02-96
Fax: 33-(0)-4-97-21-10-96
Internet: www.seavision.com
Email: sales@seavisioneurope.com

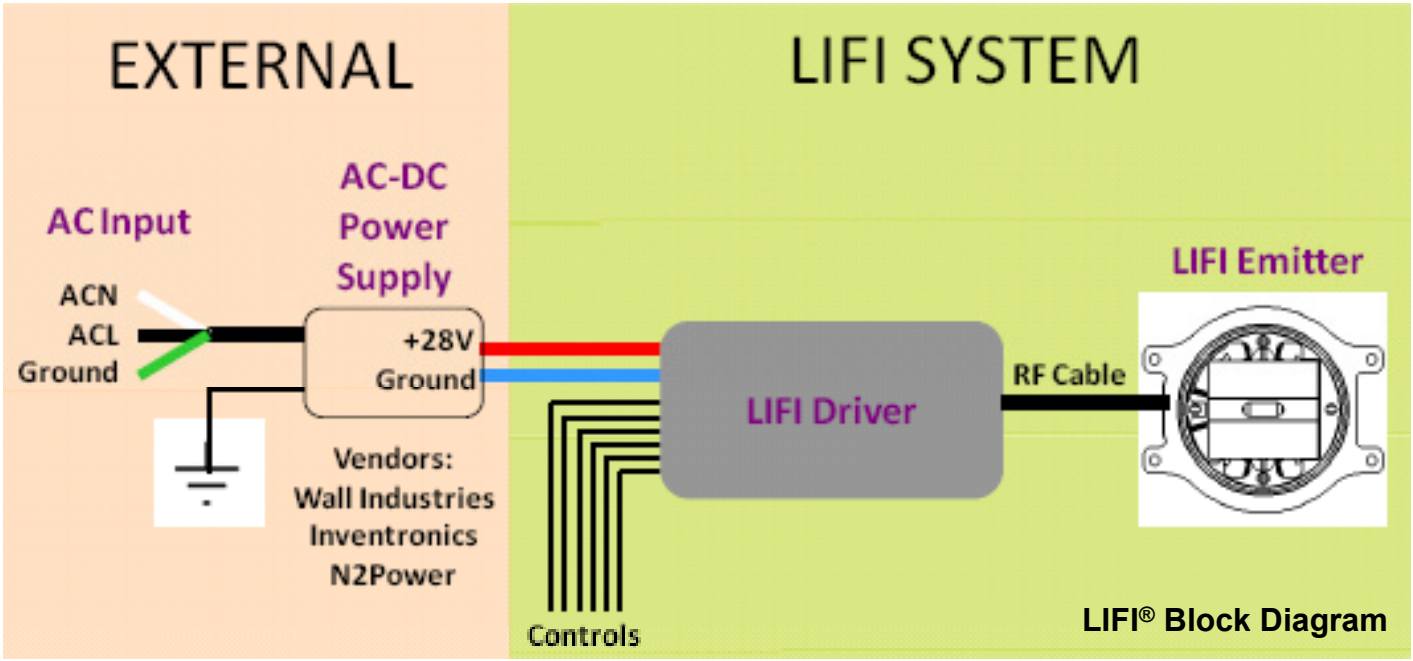

LIFI® I/O Chart

Function	I/O Type	Description	Wire Color	Levels
Vin	Input	DC input power for the lamp	Red	28V/9.5A
Power Ground	Input	Return for DC power for the lamp	Black	28V/9.5A
Lamp TxD	Output	Serial digital control line that sends status and echos commands to an external monitor/controller	Blue	see specification
Lamp RxD	Input	Serial digital control line that receives commands from an external monitor/controller	Orange	see specification
SCI Switch	Input	Analog input line which can be configured for various features for the lamp	White	0 - 24V
1-10V Dim	Input	Analog dimming control	Violet	1-10V
+5V	Output	DC voltage for driving external add ons	Brown	y A
Signal Ground	Input	DC return	Black	n/a

LIFI® Lamp Control

The lamp has 4 modes of control enabling a broad range of features

Features	Lamp Mode			
	Basic	SCI Switch	Digital (TxRx)	Digital/SCI
Power On/Off Switch	X	X		X
Digital On/Off		X	X	X
Digital Dimming		X	X	X
Lamp Status			X	X
1-10V Dimming	X	X	X	X
Occupancy Sensing	X		X	
Daylighting	X	X	X	X
Remote/Local Control				X
Wireless Dimming	X	X	X	X
Networking (wired/wireless)		X	X	X

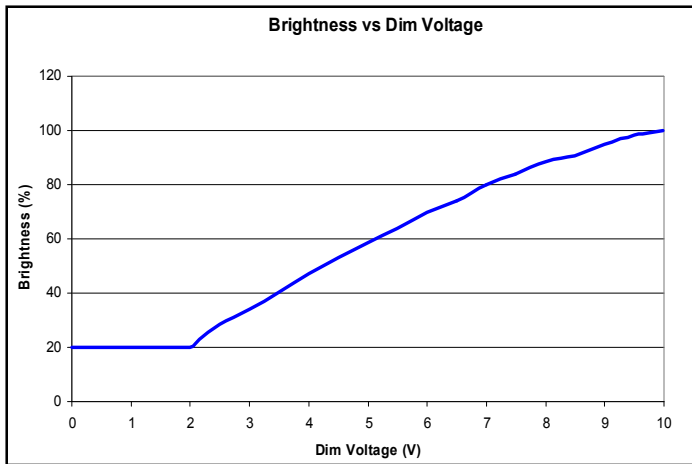

LIFI® Lamp 1-10V Dimming

The dimming range is 20% to 100%

Below 2V lamp will stay at 20%

If dimming voltage is below 0.5V at start-up, lamp will ignore dimming voltage setting until it increases to above 0.5V

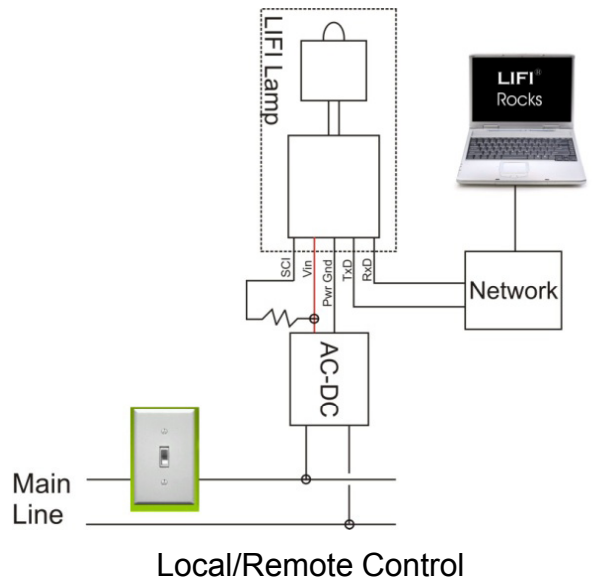
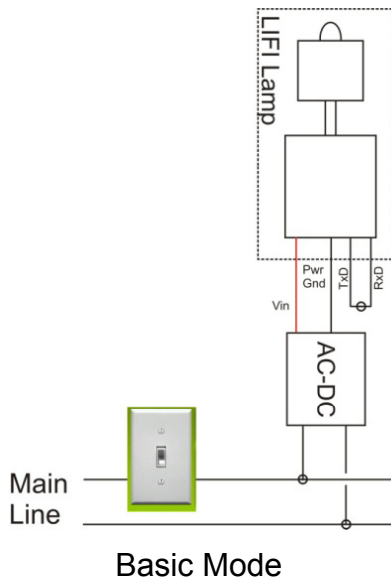

LIFI® Lamp TxRx Control and Graphical User Interface (GUI) Demonstration

Initialization (State 10)

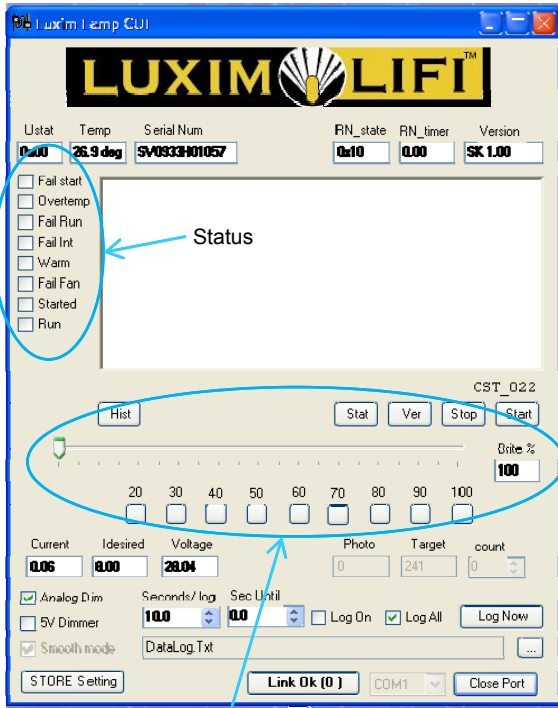

DIM Controls Slider simulates 1-10V dimmer

Run (State 70)

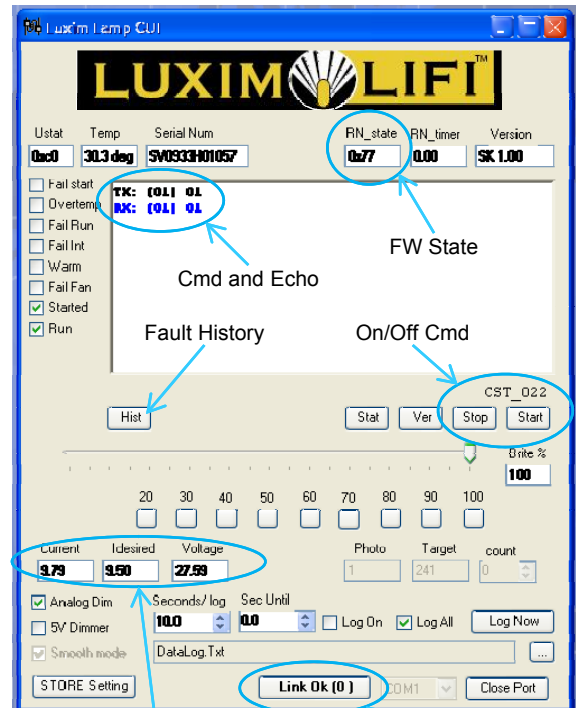

Operating Parameters

Link Status

Commands

Command	Reply	Action
Start Lamp	Y	Starts lamp
Stop Lamp	Y	Stops lamp
Version	4 bytes	Returns last four bytes of the FW revision
Return Status	Lstat	See table
Set Dimming	Echo of Command	Sets lamp brightness from 100 to 20% (128 levels)
Return Extended Status	Lstat1, Lstat2	See table
Return Current and Temp	Current & Temp	Returns DC current of the lamp and the driver temp
Return All Status	Lstat1, Lstat2, Current and Temp	See table

LIFI® Communications Protocol

Lstat1	Type
Failed Start	Alarm
Overtemp	Alarm
Too Warm	Warning
Failed Run	Alarm
Temp Sense Failure	Warning
Run	Status
Ignition	Status

Status/Alarms

Lstat2	Type
Vin Fail	Alarm
Vin Low	Warning
Low Current	Alarm
Vin High	Warning

See Luxim document number 98-02554-CS01 "Lamp Communications Specification, Protocol No. 1" for more details

LIFI® Lamp Behaviors

- Lamp will ignore all commands until it reaches "State 70"
 - This includes dimming, stop and status commands
- Lamp has a built in re-strike delay, it will ignore start commands until the timer times out
 - If a start command has been sent, lamp will wait for timer to time out, then start
- For Thermal Roll off, the minimum dimming level is 70%
- Dimming level states are set by current since no photodiode is available
 - Typically this gives +/-5% accuracy on brightness